

Integrate Process Simulation and Process Synthesis

DOMINIC CHWAN YEE FOO

UNIVERSITI TEKNOLOGI MALAYSIA

ZAINUDDIN ABDUL MANAN

UNIVERSITI TEKNOLOGI MALAYSIA

MURUGAN SELVAN

WINSIM, INC.

MICHAEL LYNN MCGUIRE

WINSIM, INC.

The design of a new process using computer simulations to analyze a process flowsheet based on the onion model can save time, effort and, ultimately, money.

The design of a chemical process involves synthesis and analysis. Process synthesis is the overall development of a process flowsheet by combining individual steps (equipment and operating conditions) into an optimal arrangement. Process analysis breaks down the flowsheet to evaluate the performance of each individual element as well as how the overall process would perform, typically by a process simulator.

Process analysis is often performed after the synthesis task has been completed. The major disadvantage of this approach is that if the flowsheet is found to be infeasible during the analysis stage, the synthesis task must be repeated before the next analysis step can take place. This rework can be avoided if the flowsheet is synthesized with the use of a process synthesis model and simulation tool.

This article shows how these tools can be used hand-in-hand to generate a reasonably good process flowsheet. This is particularly useful for evaluating a new process path or generating alternatives for new process development.

Table 1. Hierarchical approach to process design (1, 2).

1. Batch vs. continuous
2. Input-output structure of the flowsheet
3. Recycle structure of the flowsheet
4. General structure of the separation system
 - Vapor recovery system
 - Liquid recovery system
5. Heat exchanger network

Process synthesis models

Two important process synthesis models are the hierarchical approach outlined in Table 1 (1, 2) and the “onion model” illustrated in Figure 1 (3, 4).

The first attempt at combining process synthesis and analysis during the development of a new process employed the hierarchical approach to synthesizing a hydrodealkylation

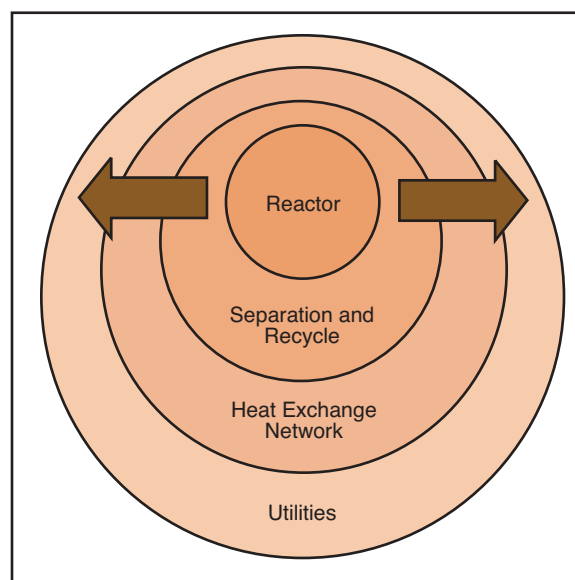

■ Figure 1. The onion model of process design (4, 5).

Process Simulation

process in an equation-based process simulator (5). The main drawback of this approach is that equation-based process simulators often require much time to write the software code before the simulation can be performed. Modular-based process simulators provide an effective means of handling the process simulation tasks.

The onion model is an alternative way to present the hierarchical approach to process design. Process design begins at the center of the onion, with the reactor, and proceeds outward. The reactor design influences the separation and recycle structures (the second layer of the onion), which are designed next. The reactor, recycle and separator structures dictate the overall heat-recovery requirements, so the heat-recovery network design comes next. Finally, the process utility systems are designed to provide additional heating and cooling requirements that cannot be satisfied through heat recovery. This model emphasizes the sequential and hierarchical nature of process flowsheet synthesis.

However, the onion model of process synthesis requires the use of a process analysis tool as well. Synthesis decisions made at each layer of the onion model may require a detailed analysis — and this is the role of a process simulator. Simulation is performed at each individual layer after new units are added or new decisions are made. This ensures that a feasible process flowsheet (in terms of mass and energy balances, operating conditions, etc.) is developed at each layer of the onion. Optimization may also be performed on each newly added unit to identify the optimum design variables (hardware optimization) as well as its operating conditions (parametric optimization).

The heart of the process — the reactor

Synthesis of a new process flowsheet should start at the heart of the chemical process, *i.e.*, the reactor system. This is where raw materials are converted into valuable products. When synthesizing and modeling a reactor system, the process designer must consider the following questions:

- What is the right reactor model (continuous stirred-tank reactor, plug-flow reactor, etc.), and what are its operating conditions (isothermal, adiabatic, constant outlet temperature, vacuum, etc.)?
- How should the product conversion and yield be determined?
- Is a catalyst needed in the reactor system modeling?

Answers to the first two questions can be found in the literature for a wide variety of reactions. When multiple sets of operating conditions exist, process simulators can serve as a tool for comparing the viable options. Simulation provides more information than the available literature in terms of heating or cooling requirements, operating conditions, and so on.

Catalyst modeling can usually be omitted from reactor modeling, provided mass and energy balances are the only targets of the simulation. However, if a catalyst used in the process involves a phase change, including it in the analysis will result in a more complete analysis of the reactor system's heating requirements.

Layer 2 — separation and recycle

After the reactor system synthesis and modeling is finished, the focus shifts to the second layer of the onion model. Products and any byproducts formed in the reactor need to be separated from unconverted reactant for further purification, while the unconverted raw material is recycled back to the reactor.

Separation system. Separation systems can be broadly classified as liquid or vapor separations. When a reactor effluent contains a mixture of liquid and vapor, a phase separator such as a flash column is normally used to separate the phases before they enter into their respective separation systems (Figure 2).

If a flash column with two degrees of freedom is employed, the designer must specify two process variables for the modeling. For simplicity, temperature and pressure (or pressure drop) are frequently used.

Vapor separation systems include condensers, flash tanks, absorbers, adsorbers, and gas separation membranes. These unit operations are normally used to purify a vapor recycle stream before it re-enters the process. A purge stream is always employed to avoid undesired contaminant build-up.

Liquid separation systems include distillation (including extractive distillation), solvent extraction, stripping, filtration (including membrane separation), centrifugation, and so on. The selection of the appropriate separation process has been discussed extensively in design textbooks (*e.g.*, 2, 6, 7) and will not be covered here. Because distillation is so widely used, distillation column modeling will be discussed in detail here.

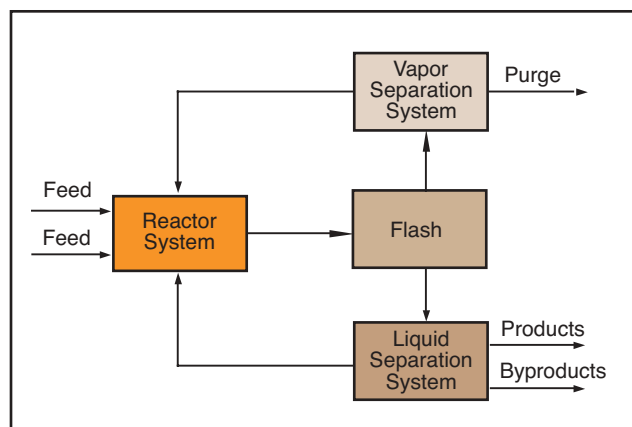

■ Figure 2. The overall separation scheme consists of vapor, liquid and flash separations (1, 2).

Specifications required for the modeling of a distillation column typically include:

- *number of theoretical trays.* A good initial estimate can often be obtained using short-cut methods such as the Fenske equation (2) or a simplified separation model available in a simulator.
- *column top and bottom temperatures.* Estimates obtained from short-cut modeling will often lead to faster convergence during column simulation.
- *column pressure.* Either the top or bottom column pressure is normally set by the column designer, or a column pressure drop is specified based on the column top pressure.
- *feed tray location(s).* Feed tray locations are selected based on such considerations as energy conservation (both feed stream and feed tray have the same temperature) and required product purity (a higher feed tray location might affect the top product stream composition), among others.
- *estimated product flowrates.* Some simulators require an estimate of the top and bottom product flowrates for the initialization of the column convergence calculations. (This value will be different from the desired product flowrate specified as the convergence criterion during the simulation.)

Most column modeling for non-complex mixture separations will converge without much difficulty. Occasionally, column modeling fails to converge. The following steps can be taken to aid the convergence of a column:

1. Evaluate thermodynamic choices, especially K-values.
2. Generate initial guesses using a short-cut method.
3. Look for unachievable and impossible specifications (for example, reboiler duty that vaporizes the entire feed, product specifications that violate the column material balance, etc.).
4. Simplify choices for heat and material balance specifications. Avoid complex approaches that set specifications (e.g., component recoveries, reflux ratios, and reboiler ratios) for the top and bottom streams that might be in conflict with each other.

Recycle system. Recycling is the tricky part of flowsheet modeling. A good start (for beginners) in modeling a recycle loop is to use the concept of a “tear stream” (8).

As shown in Figure 3, the recycle stream after unit F is considered as two separate tear streams, R_1 and R_2 . After unit A and B are solved, the simulation moves to unit C. Some initial guesses for the tear stream R_1 are made so the simulation can proceed to units D, E and F. After unit F converges, the resulting flowrate of stream R_2 is compared to the initial guess for R_1 . If the values agree to within a specified tolerance, it is likely that the simulation model has converged. The calculated value of R_2 is then used in place of R_1 in unit C and the simulation is rerun.

If tear streams R_1 and R_2 do not agree to within the specified tolerance, the initial guess for R_1 is revised and the simulation is rerun (without connecting the recycle stream to unit C).

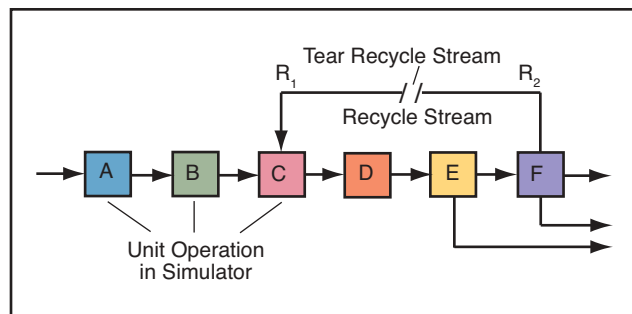

■ Figure 3. The tear stream concept is used in recycle simulation (8).

Previous CEP articles (9, 10) provided some good suggestions to aid the recycle simulation. Here are a few more:

- Maintaining product specification remains the highest priority of the process.
- Take note of the changes in feed temperature and pressure.
- Beware of the accumulation of unwanted pollutants in the process loop. A purge stream is important to ensure that the recycle system does not trap unwanted material.

An additional tip to speed up the recycling loop convergence is to increase the convergence tolerance at the initial stage of the recycling simulation. When the flowsheet has converged at this larger tolerance, the convergence tolerance is then reduced. This will enable the flowsheet to converge faster than if a tight convergence tolerance is specified at the initial stage. One can also explore various optimization options within the recycle system associated with the reaction and separation systems of the process (4).

Layer 3 — the heat exchange network

The process heating and cooling loads are determined after the process structure within the two inner layers of the onion model (i.e., the reactor, and separation and recycle systems) has been finalized. It is now time to design and model the heat exchange network (HEN). This is usually done using the well-established tool of process integration, which divides the HEN design procedure into two stages — utility targeting, and network design. The details of this are beyond the scope of this article, and readers are referred to Refs. 2, 3, 6 and 7.

After a preliminary network has been synthesized, the process flowsheet will normally undergo a complete re-simulation to verify the energy balances. Often, more recycle loops will be involved as the process streams that were used for process-to-process heat exchange are now interconnected. The tear stream concept is also useful at this stage.

Layer 4 — utilities

After the heat exchange network has been synthesized, the outermost layer of the onion model — i.e., the utility system — is addressed. The selection of hot and cold utilities is another well-established application of process integration (3,

Process Simulation

Table 2. Molar feed flowrate for each component in the production of *n*-octane (example).

Components	Flowrate, kg-mol/h	Specification
Nitrogen, N ₂	0.1	T = 30°C P = 20 psia
Ethylene, C ₂ H ₄	20	
<i>n</i> -Butane, C ₄ H ₁₀	0.5	
<i>i</i> -Butane, C ₄ H ₁₀	10	

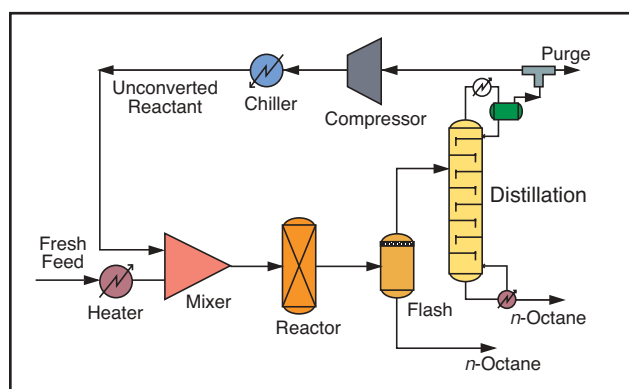

■ Figure 4. The preliminary flowsheet for the production of *n*-octane after completion of onion model layers 1 and 2.

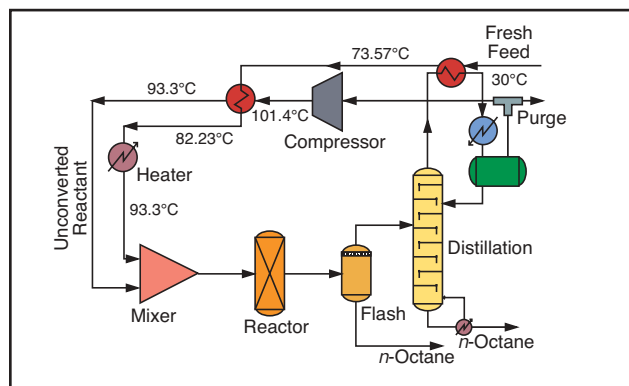

■ Figure 5. The complete flowsheet with a heat-integrated distillation column.

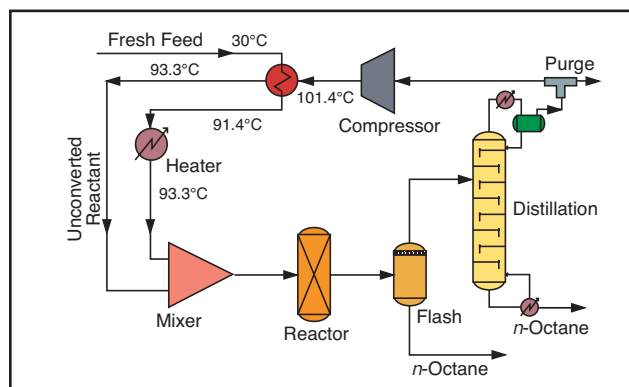

■ Figure 6. The complete flowsheet with a stand-alone distillation column.

6, 7). Other options to be explored include the placement of the heat pump and heat engine.

A process simulator is a useful tool to evaluate the selected utilities. Often, a simulated process flowsheet provides a good picture of how well a process is likely to perform after start-up.

Example: production of *n*-octane

The onion model synthesis and simulation technique will be used to develop a process flowsheet for *n*-octane (C₈H₁₈) production from ethylene (C₂H₄) and *i*-butane (C₄H₁₀). Component flowrates (with some impurities) and stream specifications for the fresh feed are given in Table 2.

DESIGN II for Windows is used as the simulation tool. This modular-based software has 886 components in its databank and uses the sequential-modular approach to perform its calculations. Various thermodynamic models can be loaded into the simulation.

Flowsheet development. Ethylene and *i*-butane react isothermally in a stoichiometric isothermal reactor at 93°C to produce *n*-octane. The key component that limits the reaction conversion is taken as ethylene, with an overall conversion of 98%. The pressure drop across the reactor is specified at 5 psi. The reaction is:



After the reactor simulation has converged, the synthesis and analysis task focuses on the separation and recycle systems. A flash column is added to the reactor effluent to separate the unconverted raw materials from the desired product. A pressure drop of 2 psi is introduced, while the operating temperature is maintained the same as that of the reactor. The more-volatile compounds (ethylene, *i*-butane, and other impurities) are flashed to the top product stream together with a small portion of the heavier product, *n*-octane, while the remaining *n*-octane leaves at the bottom. An additional separation unit is needed to recover the *n*-octane product from the top stream.

Distillation is then added to the flash column's top product stream to recover *n*-octane. The short-cut design method determines that this column has 10 theoretical trays and operates at 15 psia. The remaining *n*-octane component is recovered at the column bottom while the volatile components leave from the column top. Since the *n*-octane separation involves both the flash and distillation models, parametric optimization is performed to determine the best combination of operating parameters in these models for optimal *n*-octane recovery.

The unconverted raw material leaving at the distillation top stream is now pure enough for recycle. A purge stream is added before the stream is recompressed, reheated and sent back to the reactor. The tear stream concept is utilized to facilitate convergence of the recycle stream. Figure 4 is a preliminary process flowsheet based on the synthesis and simulation conducted this far.

Next, the design of the heat exchange network and utility system will be handled simultaneously. Stream enthalpy data needed for the analysis is extracted from the converged flowsheet in Figure 4. After the HEN is designed using process integration techniques, the simulation is re-run to verify the overall mass and energy balances for the heat-integrated flowsheet (Figure 5). The tear stream concept is utilized at this stage since the integrated process streams are considered as recycle streams in the sequential modular approach (*e.g.*, the raw material recycle stream in Figure 5).

Alternatively, if distillation is not preferred for the heat integration scheme because of controllability reasons, the alternative flowsheet is that shown in Figure 6. This gives the process designer another option for comparison (*e.g.*, energy, controllability, complexity, etc) during process development.

Closing thoughts

The final advice to simulation users is this: Check the simulation results and don't accept that everything is as it appears. The garbage-in, garbage-out (GIGO) principle applies to all computer models (11). They are not smart enough to identify wrong information provided by the user, and in turn, they produce poor results without the user's awareness (12, 13).

Also, the simulator's physical property system is not a

black box. Rather, it is a well-developed set of rules, correlations and relationships that can execute complex calculations very quickly without violating first principles.

Simulation does not replace that most useful of all tools of a chemical engineer — common sense (14). Always use engineering judgment to evaluate simulation errors or suspicious results to find their source. Computing efforts are nothing but speedy number crunchers that have logical clues, fingerprints and reasons. It is just a matter of tracking them down with less time using fundamentally sound principles. CEP

DOMINIC CHWAN YEE FOO is a research associate at the Chemical Engineering Pilot Plant (CEPP) at the Universiti Teknologi Malaysia (Phone: +60-7-553-1662; Fax: +60-7-556-9706; E-mail: cyfoo@cepp.utm.my). His main research interests include process synthesis and design as well as process integration via pinch analysis. He has extensive training in using process simulators for process modeling and debottlenecking of continuous and batch processes. He obtained his BEng and MEng degrees in chemical engineering from the Universiti Teknologi Malaysia. He is a member of the Institute of Chemical Engineers Malaysia (IChemE) and the Institution of Chemical Engineers (IChemE).

ZAINUDDIN A. MANAN is an associate professor and head of the Chemical Engineering Dept. at the Universiti Teknologi Malaysia (Phone: +60-7-553-5512; Fax: +60-7-558-1463; E-mail: zain@fkkksa@utm.my). For 15 years, he has been extensively involved as a researcher, consultant and trainer for the chemical process industries in the area of process systems design and process improvement, with an emphasis on efficient energy utilization (pinch analysis) and waste minimization. He received a BSc in chemical engineering from the Univ. of Houston, an MSc in process integration from the Centre for Process Integration at the Univ. of Manchester Institute of Science and Technology, and a PhD in chemical engineering from the Univ. of Edinburgh. He is a member of the IChemE and IChemE.

MURUGAN S. SELVAN is a support engineer at WinSim, Inc. (Sugar Land, TX; Phone: (281) 565-6700 x106; Fax: (281) 565-7593; E-mail: support@winsim.com). He is responsible for providing technical guidance, quality and training in the areas of physical properties and chemical process industries modeling needs of process simulation users. He received a BS from Annamali University - India and an MS and PhD from the Univ. of Alabama, all in chemical engineering. He is a member of AIChE.

MICHAEL LYNN MCGUIRE is president of WinSim, Inc. (Phone: (281) 565-6700 x102; Fax: (281) 565-7593; E-mail: lmc@winsim.com). He has been responsible for implementing and developing process simulation software for over 20 years. He earned his BS in mechanical engineering from Texas A&M Univ. and is a member of AIChE.

Acknowledgement

The authors acknowledge Sivakumar Kumaresan for reviewing this article.

Literature Cited

1. **Douglas, J. M.**, "A Hierarchical Decision Procedure for Process Synthesis," *AIChE Journal*, **31** (3), pp. 353–362 (Mar. 1985).
2. **Douglas, J. M.**, "Conceptual Design of Chemical Processes," McGraw Hill, New York (1988).
3. **Linnhoff, B., et al.**, "A User Guide on Process Integration for the Efficient Use of Energy," IChemE, Rugby, U.K. (1982).
4. **Smith, R., and B. Linnhoff**, "The Design of Separators in the Context of Overall Processes," *Chem. Eng. Res. Des.*, **66**, pp. 195–228 (May 1988).
5. **Lott, D. H.**, "Simulation Software as an Aid to Process Synthesis," in "Understanding Process Integration II," Crump, P. R., et al., eds., IChemE, Rugby, U.K., pp. 1–22. (1988).
6. **Smith, R.**, "Chemical Process Design," McGraw Hill, New York (1995).
7. **Seider, W. D., et al.**, "Product and Process Design Principles: Synthesis, Analysis and Evaluation," Wiley, Hoboken, NJ (2003).
8. **Turton, R., et al.**, "Analysis, Synthesis and Design of Chemical Processes," Prentice Hall, Upper Saddle River, NJ (1998).
9. **Schad, R. C.**, "Don't Let Recycle Streams Stymie Your Simulation," *Chem. Eng. Progress*, **90** (12), pp. 68–76 (Dec. 1994).
10. **Schad, R. C.**, "Make the Most of Your Process Simulation," *Chem. Eng. Progress*, **94** (1), pp. 21–27 (Jan. 1998).
11. **Petrides, D. P., et al.**, "The Roles of Process Simulation in Pharmaceutical Process Development and Product Commercialization," *Pharmaceutical Engineering*, **22** (1), pp. 1–8 (Jan./Feb. 2002).
12. **Agarwal, R., et al.**, "Uncovering the Realities of Simulation," Parts 1 and 2, *Chem. Eng. Progress*, **97** (5), pp. 42–52 and (6), pp. 64–72 (May, June 2001).
13. **Le, N. D., et al.**, "Doublecheck Your Process Simulations," *Chem. Eng. Progress*, **96** (5), pp. 51–52 (May 2000).
14. **Carlson, E. C.** "Don't Gamble with Physical Properties for Simulations," *Chem. Eng. Progress*, **92** (10), pp. 35–46, (Oct. 1996).

Further Reading

- Gupta, V. S., and N. D. Messey**, "Solving Unsteady State Problems Using ChemCAD, a Steady-State Process Simulator," AIChE National Spring Meeting, Houston, TX (1995).
- Horwitz, B. A.**, "Avoid Nausea when Solving Dynamic Problems," *Chem. Eng. Progress*, **92** (3), pp. 41–51 (Mar. 1996).
- Horwitz, B. A.**, "Make the Most of Your Process Design Software," *Chem. Eng. Progress*, **90** (1), pp. 54–57 (Jan. 1994).
- Horwitz, B. A.**, "Are You 'Scotomatized' by Your Simulation Software?," *Chem. Eng. Progress*, **92** (9), pp. 68–71 (Sept. 1996).
- Horwitz, B. A.**, "Hardware, Software, Nowhere," *Chem. Eng. Progress*, **94** (9), pp. 69–74 (Sept. 1998).
- Kister, H. Z.**, "Can We Believe the Simulation Results?," *Chem. Eng. Progress*, **98** (10), pp. 52–58 (Oct. 2002).
- Westerberg, A. W., et al.**, "Process Flowsheeting," Cambridge University Press, Cambridge, U.K., (1979).